

## DESIGN & INTEGRATION

Phone 905-669-8497 • Fax: 905-669-3607

E-mail: Sales@designintegration.com

## LIQUID LAMINATION LINE

**500-1000 sqft/shift  
(50-100 lites/shift)**

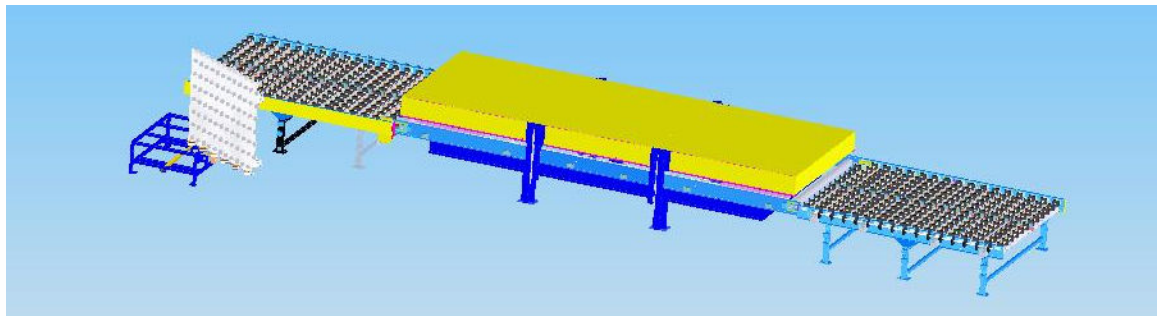

### System Specifications:

- Single Fill table with assembly modification
- In Feed Conveyor
- 20' UV Oven Hydraulic Lift design
- Out Feed Conveyor with side unload
- 500-1000 sqft/shift
- 50-100 lites/shift (10sqft/lite)

### Requirements:

240V 3 PH, 120V, 60/80 PSI air  
3 people

### Ordering Information

Reference Model: UV LINE- OP6

Specify: Height

WWW.GLASSMACHINE.CA

# DESIGN & INTEGRATION

Phone 905-669-8497 • Fax: 905-669-3607

E-mail: Sales@designintegration.com

## LIQUID LAMINATION LINE

**500-1000 sqft/shift**  
**(50-100 lites/shift)**

WWW.GLASSMACHINE.CA

